

SK22 THRU SK220

SURFACE MOUNT SCHOTTKY BARRIER RECTIFIER



康比電子
HORNBY ELECTRONIC

REVERSE VOLTAGE: 20 to 200 VOLTS
FORWARD CURRENT: 2.0 AMPERE

FEATURES

- Plastic package has Underwriters Laboratory Flammability Classification 94V-0
- For surface mounted applications
- High current capacity
- Built-in strain relief
- Low profile package
- Metal to silicon rectifier. majority carrier conduction
- High surge capacity
- Low power loss, high efficiency
- For use in low voltage high frequency inverters, free wheeling, and polarity protection applications
- High temperature soldering : 250°C /10 seconds at terminals

MECHANICAL DATA

Case: Molded plastic, DO-214AA(SMB)
Terminals: Axial leads, solderable per MIL-STD-750, method 2026 guaranteed
Polarity: Color band denotes cathode end
Packaging: 12mm tape per EIA STD RS-481
Weight: 0.002 ounce, 0.064 gram

DO-214AA(SMB)

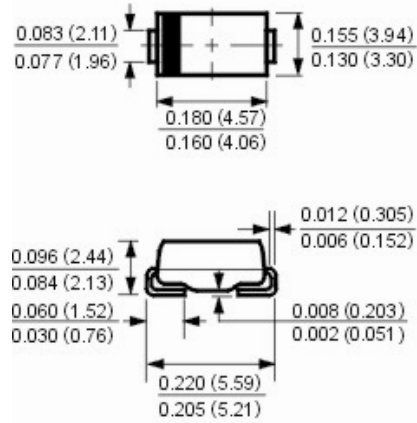

Dimensions in inches and (millimeters)

Maximum Ratings and Electrical Characteristics

Ratings at 25°C ambient temperature unless otherwise specified.
Single phase, half wave, 60Hz, resistive or inductive load.
For capacitive load, derate current by 20%.

	Symbols	SK22	SK23	SK24	SK25	SK26	SK28	SK29	SK210	SK215	SK220	Units
Maximum Recurrent Peak Reverse Voltage	V_{RRM}	20	30	40	50	60	80	90	100	150	200	Volts
Maximum RMS Voltage	V_{RMS}	14	21	28	35	42	56	64	71	106	141	Volts
Maximum DC Blocking Voltage	V_{DC}	20	30	40	50	60	80	90	100	150	200	Volts
Maximum Average Forward Rectified Current at T_L (See Fig. 1)	$I_{(AV)}$	2.0										Amp
Peak Forward Surge Current, 8.3ms single half-sine-wave superimposed on rated load (JEDEC method)	I_{FSM}	50										Amp
Maximum Forward Voltage at 2.0A (Note 1)	V_F	0.50		0.70		0.85		0.95				Volts
Maximum Reverse Current at $T_A=25^\circ\text{C}$ at Rated DC Blocking Voltage $T_A=100^\circ\text{C}$	I_R	0.5										mAmp
Typical Thermal Resistance (Note 2)	$R_{\theta JA}$	75										°C/W
	$R_{\theta JL}$	17										
Operating Junction Temperature Range	T_J	-55 to +125										°C
Storage Temperature Range	T_{stg}	-55 to +150										°C

NOTES:

- 1- Pulse test: 300µs pulse width, 1% duty cycle
- 2- P.C.B. mounted with 0.3 x 0.3" (8.0 x 8.0mm) Copper Pad Areas

SK22 THRU SK220

SURFACE MOUNT SCHOTTKY BARRIER RECTIFIER

RATINGS AND CHARACTERISTIC CURVES

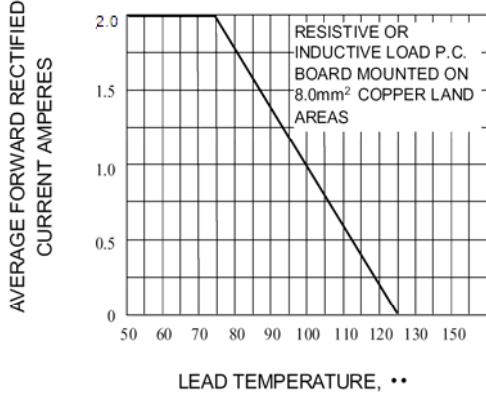

Fig. 1-FORWARD CURRENT DERATING CURVE

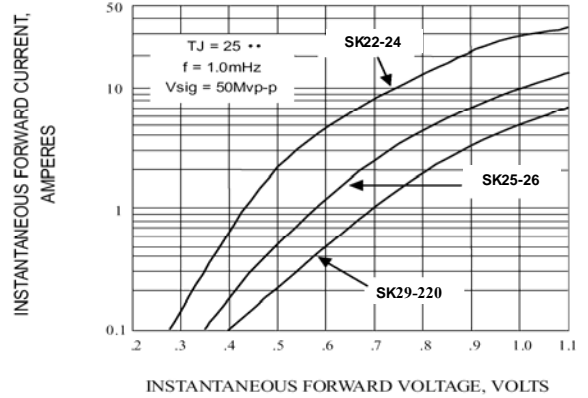

Fig. 2-TYPICAL INSTANTANEOUS FORWARD CHARACTERISTICS

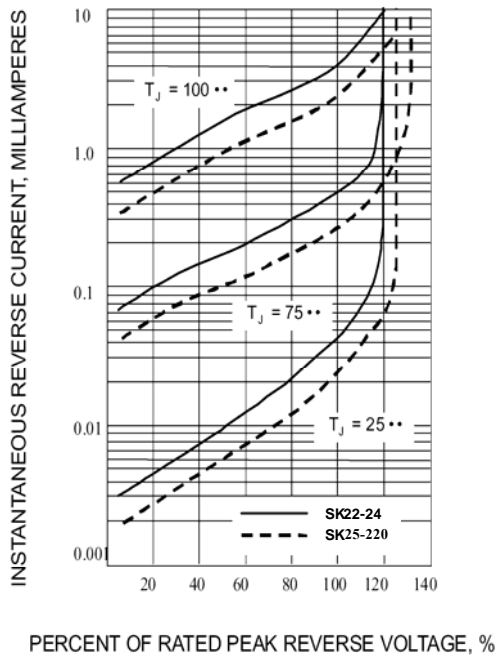

Fig. 3-TYPICAL REVERSE CHARACTERISTICS

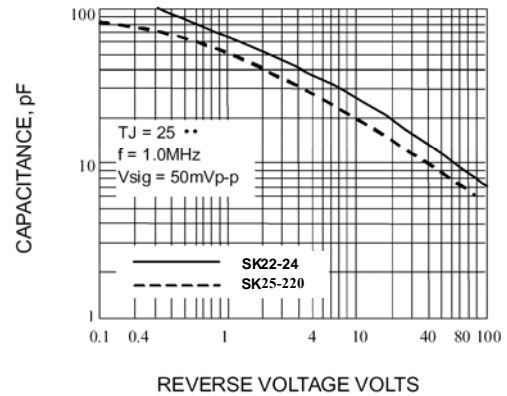

Fig. 4-TYPICAL JUNCTION CAPACITANCE

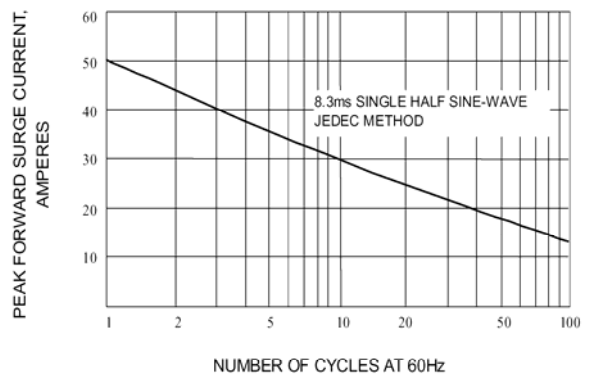

Fig. 5-MAXIMUM NON-REPETITIVE PEAK FORWARD SURGE CURRENT