

2W005M THRU 2W10M

SINGLE-PHASE SILICON BRIDGE RECTIFIER

REVERSE VOLTAGE: 50 to 1000 VOLTS
FORWARD CURRENT: 2.0 AMPERE

FEATURES

- Surge overload rating: 50 amperes peak
- Ideal for printed circuit board
- Reliable low cost construction utilizing molded plastic technique
- High temperature soldering guaranteed: 250°C/10SEC/ 9.5mm lead length at 2.3kg tension

MECHANICAL DATA

Case: Reliable low cost construction utilizing molded plastic technique results in inexpensive product
 Terminals: Leads solderable per MIL-STD-202, method 208 guaranteed
 Mounting position: Any
 Weight: 0.05ounce, 1.3gram

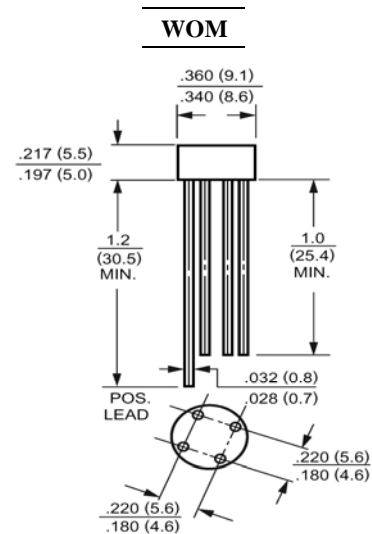

Dimensions in inches and (millimeters)

Maximum Ratings and Electrical Characteristics

Ratings at 25°C ambient temperature unless otherwise specified.
 Single phase, half wave, 60Hz, resistive or inductive load.
 For capacitive load, derate current by 20%.

	Symbols	2W005M	2W01M	2W02M	2W04M	2W06M	2W08M	2W10M	Units
Maximum Recurrent Peak Reverse Voltage	V_{RRM}	50	100	200	400	600	800	1000	Volts
Maximum RMS Voltage	V_{RMS}	35	70	140	280	420	560	700	Volts
Maximum DC Blocking Voltage	V_{DC}	50	100	200	400	600	800	1000	Volts
Maximum Average Forward Rectified Current .375"(9.5mm) Lead Length at $T_A=50^\circ\text{C}$	$I_{(AV)}$	2.0							Amp
Peak Forward Surge Current, 8.3ms single half-sine-wave superimposed on rated load (JEDEC method)	I_{FSM}	50							Amp
Maximum Forward Voltage at 2.0A DC and 25°C	V_F	1.1							Volts
Maximum Reverse Current at $T_A=25^\circ\text{C}$ at Rated DC Blocking Voltage $T_A=100^\circ\text{C}$	I_R	10.0 500							uAmp
Typical Junction Capacitance (Note 1)	C_J	40				20			pF
Typical Thermal Resistance (Note 2)	$R_{\theta JA}$	40							°C/W
Typical Thermal Resistance (Note 2)	$R_{\theta JL}$	15							°C/W
Operating and Storage Temperature Range	T_J, T_{stg}	-55 to +125							°C

NOTES:

- 1- Measured at 1 MHz and applied reverse voltage of 4.0 VDC.
- 2- Thermal Resistance Junction to Ambient and from junction to lead at 0.375"(9.5mm) lead length P.C.B. Mounted.

2W005M THRU 2W10M

SINGLE-PHASE SILICON BRIDGE RECTIFIER

RATINGS AND CHARACTERISTIC CURVES

FIG.1- MAXIMUM NON-REPETITIVE FORWARD SURGE CURRENT PER BRIDGE ELEMENT

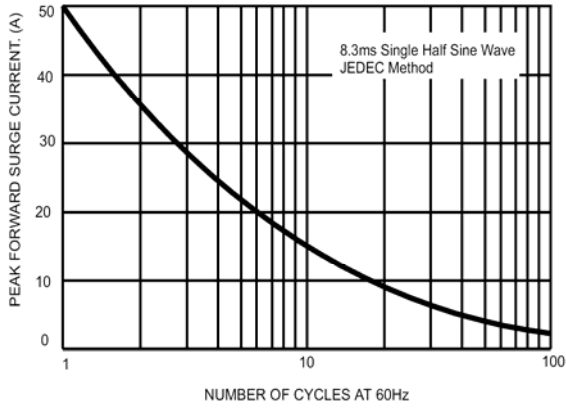

FIG.2- MAXIMUM CURRENT DERATING CURVE OUTPUT RECTIFIED CURRENT

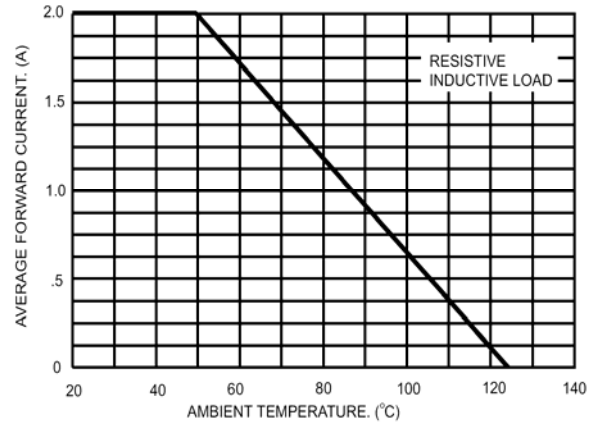

FIG.3- TYPICAL INSTANTANEOUS FORWARD CHARACTERISTICS PER BRIDGE ELEMENT

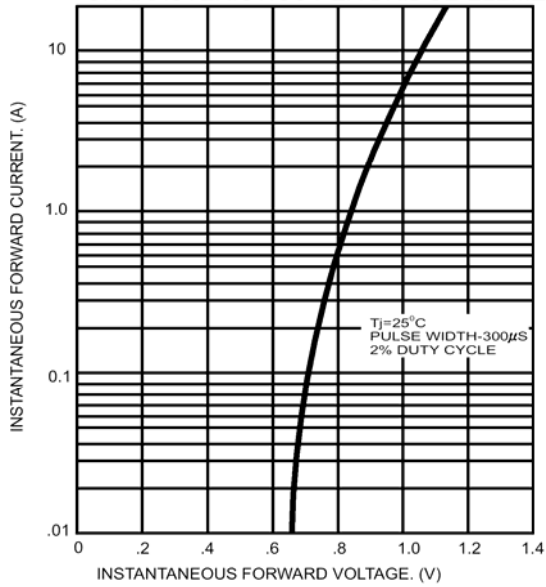

FIG.4- TYPICAL REVERSE CHARACTERISTICS PER BRIDGE ELEMENT

