

- SPECIFICATIONS:
- ELECTRICAL CHARACTERISTICS:
 - RATING:
 - CONTACT RESISTANCE: 30mΩ MAX.(INITIAL)
 - DIELECTRIC WITHSTANDING VOLTAGE: 500V AC FOR ONE MINUTE
 - INSULATION RESISTANCE: 100MΩ MIN. MEASURED BY 500V DC
 - MECHANICAL CHARACTERISTICS:
 - INSERTION FORCE : 0.3~3.0 KGF
 - WITHDRAWAL FORCE : 0.3~3.0 KGF
 - LIFE TEST: 5,000 CYCLES MIN.
 - FOR REFLOW SOLDERING LEAD-FREE PROCESS.
 - * REPRESENT CRITICAL DIMENSIONS.

SCHEMATIC	
Model	DC-005
Center Pin	1.65
	2.0
	2.5

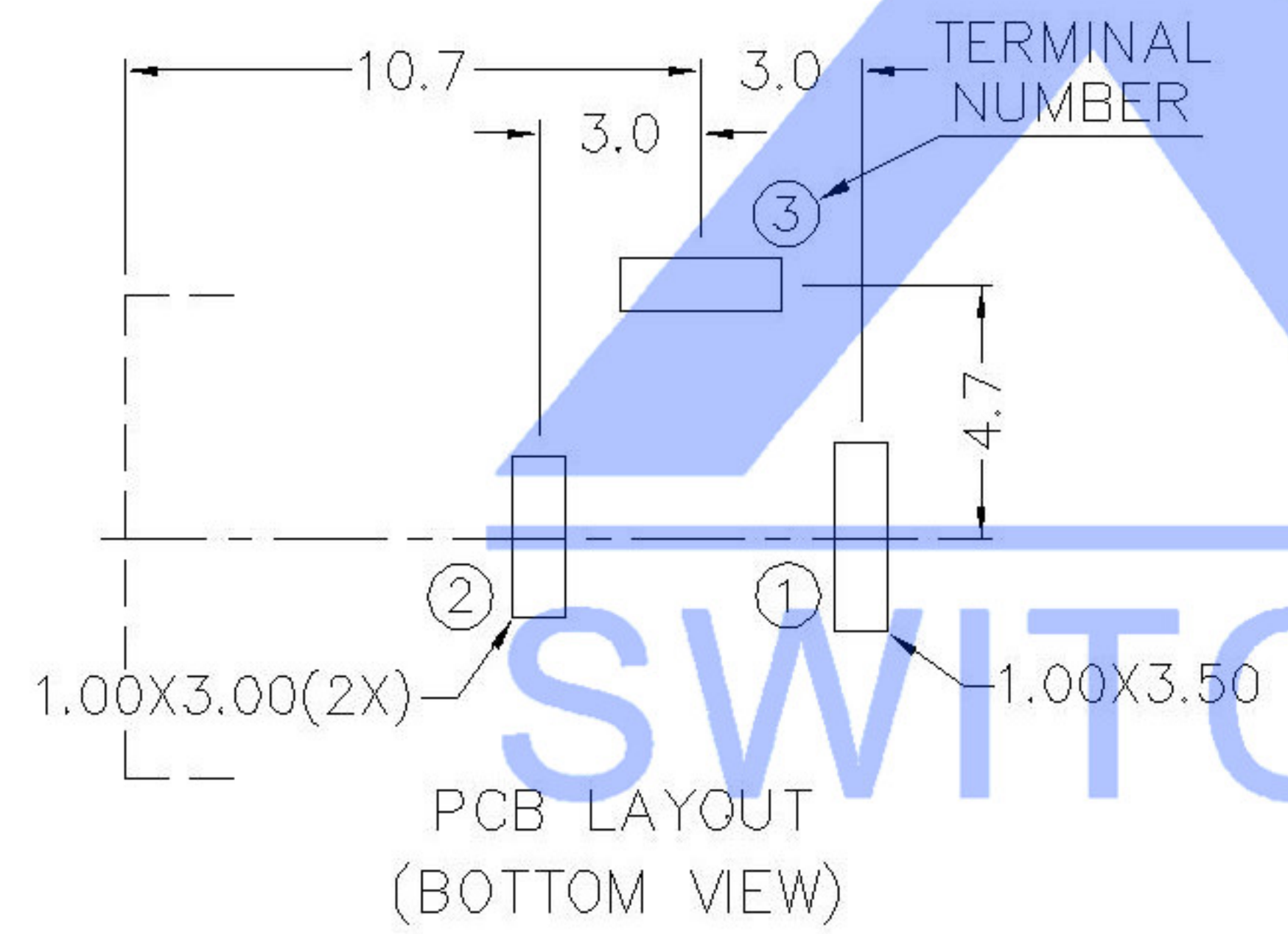

MATING PLUG
Jack Insertion Depth: 9.0 mm

	MATERIAL	PLATING
center pin	Brass	tin
terminal 1	Brass	tin
terminal 2	Phosphor Bronze	tin
terminal 3	Brass	tin
plastic	Pbt	

					ANGLAR	±5°	DSND		DATE		SCALE: N/A	MODEL TYPE: DC POWER JACK	
△X					X.X	±0.2mm	DWN		DATE		VIEW:	PART NO.:	
△X					X.XX	±0.1mm	CHKD		DATE		UNIT: mm	DWG NO.:	
△X					X.XXX	±0.05mm	APPD		DATE		SIZE: A4	DC-005-2.5A-2.0	
MARK	DESCRIPTION	DATE	REVISED	APPROVED	UNSPECIFIED TOLERANCES			XKB INDUSTRIAL PRECISION CO.,LIMITED			WEIGHT	SHEET	REVISION
REVISIONS											1.0g	1/1	A0
www.xk-dg.cn www.helloxkb.com www.helloxkb.cn													